



Corrosion Testing... also with Climate Control

Salt Spray Test Chambers SC
Corrosion Climate Alternating Test Units SC/KWT
and Walk-In Salt Spray Test Chambers

Applied Corrosion Testing...

Salt Spray Test Chambers SC / Corrosion Climate Alternating Test Units SC/KWT

The SC/KWT series salt spray test chambers are a further example of the future-oriented testing systems developed by Weiss Umwelttechnik.

The equipment adheres to the principle of combining technical function, ergonomics and design to provide the user with a testing system that is the best possible in every respect.

This is true for a great variety of technical and practical details as well as for the price/performance ratio, whereby we gave equal weight to capital and operating costs.

The series is characterised by its environmentally friendly overall design; it is absolutely corrosion-proof, has low energy requirements and is almost entirely built from recyclable materials.

The SC/KWT series of salt spray test chambers and alternating climate test equipment allows selective and reproducible accelerated corrosion testing complying with the requirements of relevant national and international standards such as DIN, ISO, ASTM, DEF, MIL-STD, etc.

The wide-angle test chamber hood allows for loading heavy or bulky test specimens from the top. Two standard sizes are available. A flat work space is provided between test space and control panel for placing small specimens before or after a test cycle.

The removable machine compartment hood provides easy access for the operator and service personnel carrying out maintenance and service work.

1. Salt fog test as specified in DIN 50 021

A salt solution is sprayed into the test chamber using the venturi principle through a nozzle located at the top of the test space. The compressed air required is heated in a pressurised humidifier and saturated with moisture before it enters the test space.

The brine solution in the venturi nozzle feeder vessel is kept at a constant level by a recirculating supply.

The heating in the test chamber ensures uniform temperature conditioning to the required set temperature. Condensation generated is drained away through a floor drain, and the corrosive test chamber atmosphere is vented through an exhaust vent.

This test is possible with the standard SC series chamber.



The advantages at a glance

- Corrosion resistant housing made from recyclable polyethylene
- Acrylic glass nozzle in spraying duct for optimum spray fog distribution
- Robust construction
- Good thermal insulation; the choice of materials guarantees long service life
- User-friendly variable positioning for test specimens
- External heating of test chamber using safe 42 volt system
- Test specimens may also be lifted into the test chamber by crane thanks to the lightweight test chamber hood which opens to 75 °
- Hydrostatic hood seal
- Ergonomic arrangement of the operating panel and display instruments
- Operation, program and set value selection via colour touch panel
- Digital set and actual value displays
- Digital fill level display on the operating panel
- Long-term tests are no problem thanks to the 180 litre capacity brine reservoir
- Easily filled with brine through a front-mounted, 125 mm Ø filler opening
- Ready-to-plug in, modular construction. Hence no need for assembly or commissioning on site
- Test chamber design provides ease of service, all parts are easily accessible through the light-weight, removable machine compartment hood.

2. Condensed water test as specified in DIN 50 017 and EN ISO 6988 [DIN 50 018]

The test space drain is closed and the test space filled with distilled or demineralised water according to the standard. The specified temperature is achieved by temperature-conditioning of the water in the bottom of the test space. Condensation water forms on the surface of the test specimen through thermal radiation from the test specimen onto the ceiling of the test chamber and walls.

The test specified in DIN 50 017 is possible with the standard SC series chamber.

EN ISO 6988 [DIN 50 018] describes a method of testing with an atmosphere containing SO₂ in a condensation water alternating climate.

This test is possible with the standard SC series chamber plus a SO₂ gas dosing device.

3. Standard climates as specified in DIN 50 014, clause 5 ambient temperature

The corrosive atmosphere in the test space is automatically vented from the test space through the exhaust air vent and the test space purged with compressed air.

This test is possible with the standard SC series chamber plus a venting device.



Corrosion alternating climate test equipment

Through the addition of certain accessories, the standard salt-spray test chambers become SC/KWT series alternating climate test chambers which can run cyclically through test conditions (e.g. those specified in 1, 2 and 3). The user may determine for himself and program the sequence, duration and number of cycles of the test procedure.

VDA test 621-415 "Paint testing, testing or road vehicle finishes under exposure to cyclically alternating climates" may be used here as an illustration of the procedure for a typical alternating climate test.

A test cycle lasts seven days and consists of

1 day = 24 h SS DIN 50 021 salt spray fog testing

4 days = 4 cycles KFW DIN 50 017 condensation water alternating climate

2 days = 48 h at ambient temperature 18 to 28 °C as specified in DIN 50 014, clause 5 ambient temperature

The test period is as agreed; it preferably lasts for 4 to 6 cycles.



Control and Equipment...

Control and programming

The Salt Spray Test Chambers are equipped with the self-monitoring, digital 32-bit measuring and control system **SIMCON/32*-NET**.

This system coordinates all control functions. Integration of the test unit into your computer network is easily possible via an Ethernet interface (RJ 45).

Input functions and display of the operating parameters are effected via the graphic colour touch panel.

Additional features:

- High-resolution colour display
- Operating and error display in clear text
- Operation by simply touching the function symbols
- Program editor and program storage for up to 100 programs
- Password protection
- Menu-guidance

Determination and display of precipitation quantities

The SC and SC/KWT models can be fitted with a fully-automatic precipitation gauge and display device. This device allows the most important variable in a salt spray test to be determined precisely.

The corrosive precipitation can be measured at up to eight measuring points in the test chamber.

The constantly updated average value of precipitation, test time and number of droplets is displayed during the course of the test.

Standard model SC series

- Programmable **SIMCON/32*-NET** control unit
- Colour touch panel
- Serial interface RS 232 C
- Precision two-component nozzle in spray duct
- Compressed air regulation unit
- Heated compressed air humidifier with water level control
- Flow metering and dosing device for brine
- Brine reservoir, 180 l
- Test specimen bracket
- Corrosion-resistant, stable support rods to hold the test specimen at bench height
- Floor grid
- Extended depth "U" profile groove on right-hand side for measuring and supply lines
- Calibration in salt spray test (+35 °C test space temperature/ +49 °C humidifier temperature)
- Calibration in condensed water test (+40 °C test space temperature)

Additional features of series SC/KWT

- Ventilation device complying with DIN 50 014, clause 5 ambient temperature
- Automatic water reservoir for DIN 50 017/EN ISO 6988 [DIN 50 018]
- Test chamber floor drain with diaphragm valve for DIN 50 017/ EN ISO 6988 [DIN 50 018]

Options SC/KWT series

- Ventilation device for DIN 50 014, clause 5 ambient temperature (standard equipment on KWT equipment)
- Demineralisation cartridge
- Air compressor
- Precipitation collector
- Precipitation measurement and display
- Measuring cable ports, each 50 mm in diameter, free choice of location on left, front or rear wall of the test chamber
- Triangular window
- SO₂ gas dosing device for EN ISO 6988 (DIN 50 018) manually, automatically only possible in combination with SC/KWT equipment
- Hood locking, safety lock switch prevents opening of hood, e. g. in case of SO₂-atmosphere
- Additional brine reservoir, 500 l
- Interface RS 422/485 network card
- Ethernet/LAN interface (100/10 MBit) in combination with **SIMPATI*** for networking
- Centronics printer interface
- Software package **SIMPATI*** for Windows 2000, Windows 2000/3000 Server and Windows XP Prof.
- Air conditioning unit
- Other sizes, e. g. 2000 l, or customised accessories are available upon request.



...Technical Description and Data

Design features

The corrosion-resistant, self-supporting polyethylene casing is in two colours, the body is similar to RAL 9002, the test chamber hood is RAL 5000 blue.

Adequate floor clearance (approx. 100 mm) for transportation and cleaning is provided by five adjustable feet.

The depth of the equipment, at 800 mm, allows it to pass through standard doors with no difficulty.

The high quality test chamber is made from special glass fibre reinforced plastic laminate and is fitted with all supply and drainage connections and housings for test specimen support rods.

The hood and test chamber are hydrostatically sealed using a "U" profile groove.

The connection for the condensation drain is located at the bottom left of the rear wall of the test chamber. The exhaust air connection is flush with the machine compartment rear wall.

The brine container is an integral part of the machine compartment.

The machinery compartment hood incorporates the operating and display panel and a work bench which can withstand a distributed load of up to 10 kg.

The level of the supply water for the pressurised humidifier is automatically regulated.

Safety devices switch the test chamber off in the event of faults such as excess temperature.

Technical Data

SC series	Type	SC 450	SC 1000
SC/KWT series	Type	SC/KWT 450	SC/KWT 1000
Test space volume		approx. 480 l	950 l
Test space dimensions with hood	Height	approx. 1,190 mm	1,190 mm
without hood	Height	approx. 740 mm	740 mm
to spray duct	Width	approx. 750 mm	1,560 mm
	Depth	approx. 570 mm	570 mm
Overall dimensions with hood	Height	approx. 1,370 mm	1,370 mm
without hood	Height	approx. 920 mm	920 mm
	Width	approx. 1,930 mm	2,730 mm
	Depth	approx. 800 mm	800 mm
Brine reservoir		approx. 180 l	
Colour		similar to RAL 9002 / RAL 5000	
Temperature range		5 K above ambient temperature to +50 °C	
– Salt spray test		5 K above ambient temperature to +45 °C	
– Condensed water test		ambient humidity to saturation	
Humidity range in SC/KWT		ambient humidity to saturation	
Temperature constancy in time		±1 K	
Air throughput in salt spray test		1.5 m ³ /h (at 0 °C and 1 bar)	
Air throughput in standard climates (only SC/KWT)		4.5 m ³ /h (at 0 °C and 1 bar)	
Compressed air		min. 4 bar / max. 10 bar connection 1/4"	
Water pressure for humidifier		demineralised or distilled water min. 3 bar / max. 5 bar 3/4" connector	
Electrical supply		208 / 220 / 230 / 240 / 254 V 1 Ph / 50 Hz and 60 Hz	
Connected load	approx.	2.0 kVA	2.6 kVA
Weight excluding brine contents (empty)	approx.	180 kg	220 kg

Installation drawing

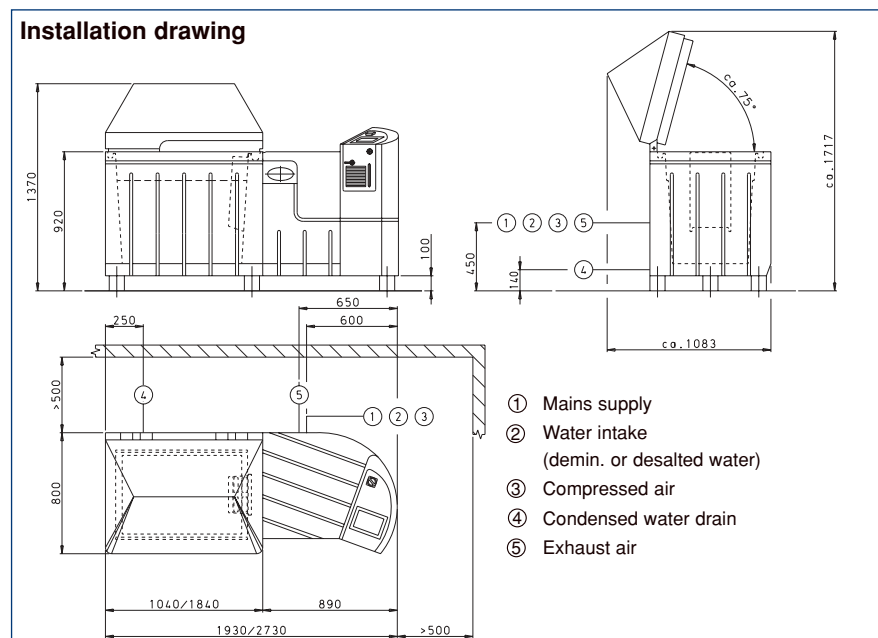

Additionally Controlled Climate...

Corrosion Climate Alternating Unit with controlled climate

In addition to the performance of salt fog and condensed water tests, the SC/KWT 1000 with climate extension allows for cycles with controlled humidity and drying/ventilation as well as combined/alternating tests with the above-mentioned cycles.

During climate tests or drying, air-conditioned or heated ambient air supplied into the test space via the air-conditioning unit incl. air-cooled refrigeration unit arranged at the backside.

A psychrometric measuring system incl. wet bulb sensor with forced wetting is installed in the exhaust air for closed loop controlled humidity.

Technical Data

The test space and overall dimensions correspond to those of the SC/KWT 1000, except for the overall depth, which amounts to 1.400 mm.

The following performance data can be realised as single or combined test:

Salt spray fog test: RT +5 K ... +50 °C / ±1 K (in time)

Condensed water test: RT +5 K ... +45 °C / ±1 K (in time)

Climate tests:

– Temperature +23 °C ... +60 °C / ≤ ±2 K (in time)
– Humidity 20 ... 95 % r. h. / ≤ ±6 % r. h. (in time)
– Dew point +10 ... +59 °C*

Drying/ventilation:

– Temperature RT +5 K ... +60 °C* / ≤ ±2 K (in time)
– Humidity ≤ 30 % r. h. (controlled)

* Temperatures > +50 °C or dew point temperatures > +49 °C require the optional hood insulation.

Standards

PVW 1210
Nissan NES M0158 + M0007
CCT I, II, IV
Volvo STD 1027, 1375*
Volvo STD 1027, 14*
GM 9540 P
Toyota TSH 1555 G
JASO M610-92
SAE J 2334
KWT-DC (without frosting)
Bosch N42AP 108
IEC 68-2-52
Renault D 172028/_ _B; ECC1*

*additional options required



...and Walk-in Salt Spray Test Chambers



In addition to the salt spray test chambers of the SC/KWT series, Weiss Umwelttechnik also offers walk-in salt spray test chambers that allow for the testing of the corrosion behaviour of large components.

Special advantages

- Corrosion-resistant interior surfaces made of GFK, shock and scratch-resistant
- Exterior surface made of aluminium, white coated
- Homogenous temperature-conditioning of test space
- Service-friendly thanks to easily accessible functional units
- Self-supporting hard foam elements that can be assembled on site
- Modular design allows for different chamber sizes
- High floor load of test space
- Sprayed brine volume can be set and measured from outside

Example

Type	SC/KWT 4300 (see picture)	
Test space volume	approx.	4.3 m ³
Lateral height	approx.	2,000 mm
Centre height	approx.	2,350 mm
Width	approx.	1,200 mm
Depth	approx.	1,800 mm
Overall dimensions		
Height	approx.	2,800 mm
Width of chamber	approx.	1,440 mm
Depth	approx.	3,140 mm
Saddle roof	approx.	40° slope
Brine reservoir		200 l
Floor load	approx.	800 kg/m ² (distributed load)
Test space heater		plastic-coated low-voltage heater
Temperature range		
Salt spray fog test		5 K above ambient temperature to +50 °C
Condensed water test		5 K above ambient temperature to +45 °C
Connected load	approx.	16 kVA
Suitable for		DIN 50 014, clause 5 ambient temperature DIN 50 017 KFW and KTW DIN 50 021 SS and ESS VDA-Test 621-415

Additional equipment

- Individual nozzles with holder, adjusting and measuring system
- Exhaust air fan with siphon
- Separate brine reservoir and mixing vessel in various sizes
- Additional air conditioning unit
- Access ramp
- Precipitation measurement and display
- Climate extension DIN 50 014 (23-50-2)

Special sizes and customised design upon request.

Test systems for professionals. Test the best ...



Corrosion climate Alternating Test Chambers Type SC 1000/+20 IM

A complete line of systems is available offering test space volumes ranging from approx. 34l to 1,540 litres, a working range from $-75 \dots +180^\circ\text{C}$ and relative humidity values ranging from 10...98% r.h.

We also offer an extensive line of field-proven test systems specially for simulating exposure to weather, temperature shock, corrosion and long-time tests for application in research, development, quality control and production.

Of course, Weiss – as one of the leading producers of environmental simulation systems world-wide – offers the entire spectrum of high-tech test systems starting from a series of cost-effective test systems up to customised walk-in chambers and in-line systems.

If it's know-how, service and reliability that you are looking for – contact Weiss Umwelttechnik.

Technical Sales Offices

Berlin

13407 Berlin-Reinickendorf · Flottenstrasse 58
Tel. (0 30) 40 99 05-10 · Fax (0 30) 40 99 05-50
eMail: berlin@wut.com

Hamburg

22459 Hamburg-Niendorf · Sperberhorst 6
Tel. (0 40) 68 59 96 · Fax (0 40) 68 52 91
eMail: hamburg@wut.com

Hannover

30853 Langenhagen · Walsroder Strasse 149
Tel. (05 11) 7 28 19-10 · Fax (05 11) 7 28 19-30
eMail: hannover@wut.com

Oberhausen

46045 Oberhausen · Mülheimer Strasse 48
Tel. (02 08) 6 20 65-10 · Fax (02 08) 6 20 65-20
eMail: oberhausen@wut.com

Stuttgart

70567 Stuttgart-Möhringen · Zettachring 10
Tel. (07 11) 90 02 45-10 · Fax (07 11) 90 02 45-30
eMail: stuttgart@wut.com

Nürnberg

90592 Schwarzenbruck · Robert-Bosch-Strasse 15
Tel. (0 91 28) 92 37 55 · Fax (0 91 28) 92 37 65
eMail: nuernberg@wut.com

München

82166 Gräfelfing · Wandlhamer Strasse 31
Tel. (0 89) 89 80 45-10 · Fax (0 89) 89 80 45-30
eMail: muenchen@wut.com

Leipzig

04105 Leipzig · Tschalkowskistrasse 14
Tel. (03 41) 9 84 57-10 · Fax (03 41) 9 84 57-30
eMail: leipzig@wut.com

Subsidiaries

Weiss Umwelttechnik Ges.m.b.H.

A-1232 Wien · Ober-Laaer Strasse 316
Tel. (01) 6 16 66 97 · Fax (01) 6 16 66 97-13
eMail: weiss.umwelttechnik-wien@schunk-group.com

Weiss Technik Belgium B.V.B.A.

B-1770 Liedekerke
Nijverheidszone · Begijnenmeers 63
Tel. (0 53) 68 10 10 · Fax (0 53) 68 10 20
eMail: sales@weiss technik.be

Weiss Technik AG

CH-8802 Kilchberg · Bändlerstrasse 29
Tel. (01) 7 16 10 66 · Fax (01) 7 16 10 76
eMail: info@weiss-technik.ch

Weiss Technik France E.U.R.L.

F-78955 Carrières sous Poissy
283, route d'Andrésey
F-78304 Poissy Cedex · B.P. 4015
Tel. (1) 34 01 11 00 · Fax (1) 39 27 37 84
eMail: info@weissfr.com

Weiss Gallenkamp Ltd.

GB-Loughborough · LE11 3GE
Units 37–38 · The Technology Centre · Epinal Way
Tel. (0 15 09) 63 15 95 · Fax (0 15 09) 21 11 33
eMail: enquiries@weiss-gallenkamp.com

Weiss Technik Italia S.r.l.

I-20013 Magenta (MI) · Via Murri, 22 – 28
Tel. (02) 97 29 16 16 · Fax (02) 97 29 16 18
eMail: info@weissitalia.it

Weiss Enet Industrietechnik B.V.

NL-4004 JP Tiel · Morsestraat 8
Tel. (03 44) 67 04 00 · Fax (03 44) 67 04 05
eMail: info@weissenet.nl

Weiss Environmental Technology Inc.

Menomonee Falls, WI 53051, USA
W146 N9300 Held Drive
Tel. (2 62) 2 53-87 30 · Fax (2 62) 2 55-13 91
eMail: info@schunkgraphite.com

China Representative Office

Shanghai Weiss Technik Co.,Ltd

Room 12G, Aibo Building, 635 LingLing Road, Shanghai, 200030, P.R.C.
Tel: (0 21)-54 59 21 20 · Fax: (0 21)-54 24 29 23
eMail: support@weisschina.com www.weisschina.com



Weiss Umwelttechnik GmbH Simulationsanlagen • Messtechnik

35447 Reiskirchen-Lindenstruth/Germany · Greizer Str. 41–49
Telefon (0 64 08) 84-0 · Telefax (0 64 08) 84-87 10
www.weiss.info · www.wut.com · eMail: info@wut.com